

NIKRO

MODEL #PDU6.5 HYBRID AIR DUCT CLEANING SYSTEM

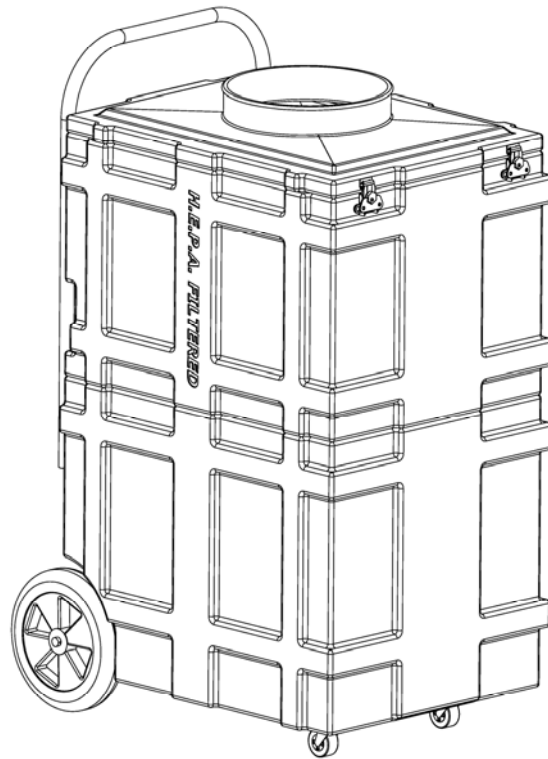

INSTRUCTION MANUAL

IMPORTANT SAFETY INSTRUCTIONS
READ ALL INSTRUCTIONS BEFORE USING THIS MACHINE.

“READ AND SAVE THESE INSTRUCTIONS”

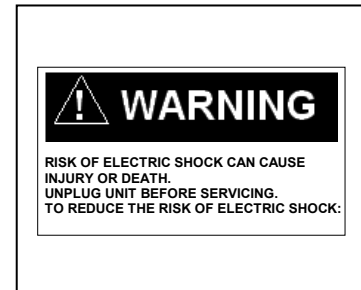

RISK OF FIRE, ELECTRIC SHOCK, OR PERSONAL INJURY

- Unit must be electrically grounded.
- Do not operate in standing water.
- If electrical components become wet, allow them to dry completely before using.
- Unplug unit before performing any maintenance, filter changes or cleaning.
- Inspect cord and plug for damage before use.
- Do not touch cord with wet hands or while standing on wet surface.
- Do not operate in flammable or explosive areas.
- Do not clean unit while plugged in.
- This unit has been designed for indoor use only.
- Do not use to exhaust hazardous or explosive materials or vapors

IMPORTANT SAFETY INSTRUCTIONS

- a. “Do not operate any unit with a damaged cord or plug. Discard unit or return it to an authorized service facility for examination and/or repair.”
- b. “Do not run cord under carpeting. Do not cover cord with throw rugs, runners, or similar coverings.
- c. Arrange cord away from traffic area and where it will not be tripped over.”



All NIKRO Industries Inc. products that have rated efficiencies of 99.97% @ 0.3 microns and/or 99.99% @ 0.3 microns, have H.E.P.A. filters that have been individually tested to meet these minimum efficiencies.

Although all the filters have been pre-tested, the possibility of leaks or filter failure due to handling, transportation, punctures, loaded filters, moisture, wear and tear, etc., does exist.

Therefore, when using this equipment in highly sensitive areas or where any release of particles above and beyond the minimum efficiencies would be detrimental and harmful to humans, plants or property; it is strongly recommended that the units be individually tested prior to their use.

This is to assure that they are maintaining the efficiency levels, which they were designed to filter out.

**FAILURE TO DO SO COULD RESULT IN SERIOUS HARM TO HUMAN LIFE,
PLANT LIFE AND/OR PROPERTY.**



BACKDRAFTING AND CARBON MONOXIDE FUMES

To prevent the backdrafting of deadly carbon monoxide, when using your PDU6.5 to create a negative pressure in a containment area, turn off all open combustion devices such as but not limited to fireplaces, hot water heaters, furnaces, boilers etc.

1115 N. Ellsworth Ave., Villa Park, IL 60181
Telephone: 630-530-0558 FAX: 630-530-0740 Toll Free: 800-875-6457

PRODUCT INSPECTION

1. Thoroughly inspect your machine for any shipping damage.
2. Your machine has already been thoroughly tested at the Nikro Industries manufacturing plant prior to shipping.
3. Please do not discard any of the packaging until you have inspected the vacuum and it is operational. Make sure the contents are intact and complete. If there are any missing parts please contact NIKRO Industries immediately.

CONTENTS

1 - #PDU6.5 – Air Duct Cleaning System



#PDU6.5

1 – #860147 – 12” x 25’ PVC Flex Duct

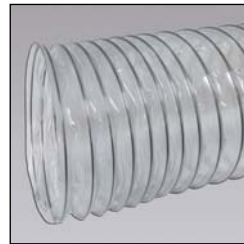

#860147

2 – #860249 – 12” Quick Connect Hose Clamps



#860249

1 – #860111 – 12” Duct Mounting Flange



#860111

1 – #862322 – Quick 220 ® Volt Converter Box



#862322

1 – #862331 – 10’ Twist Lock Lead Line Cord



#862331

2 – #860831 – 12-3 x 50’ Extension Cords



#860831

Replacement Filters:

#862328 – Bulk Collection Bag (1 installed in unit)

#862200 – Merv 11 Cube Filter (1 installed in unit)

#862323 – HEPA Filter (1 installed in unit)

ELECTRICAL

The PDU6.5 Hybrid has a 220V motor that has been designed to run on either 2 – 115V 15 or 20 amp 1 phase circuits when using the Quick 220 ® Converter Box or 1 – 220V 20 amp 1 phase circuit. This Hybrid design allows for greater vacuum power and the flexibility to obtain electrical power from alternate sources.

ELECTRICAL RATING:

220V – 13 amps – 60 hz – 1 phase

EXTENSION CORDS:

When using extension cords use a minimum of 12-3 gauge cords.
50' maximum length.

OPTION 1

ELECTRICAL SET-UP USING 2 - 115V CIRCUITS.

A separate instruction booklet for the quick 220V power converter box has been supplied with the unit. **READ AND FOLLOW ALL GENERAL AND SAFETY INSTRUCTIONS WITHIN THIS MANUAL**

Step 1) Connect power cord plug “A” from the quick 220V ® converter box to a 110/115V AC outlet. (See photo 1) (NOTE: DO NOT PLUG INTO A GFCI OUTLET) The quick 220V power supply box will click as plug is inserted into the outlets. If a click is not heard refer to the quick 220 manual, troubleshooting paragraph 4.

Step 2) Connect power cord plug “B” from the quick 220V ® converter box to other 110/115 AC outlets (See photo 2) (NOTE: DO NOT PLUG INTO A GFCI OUTLET) until the “220 Volts” light on the Quick 220V converter illuminates. (See photo 3) When the “220 Volts” light illuminates, 220 Volts are available and ready for use. IF “220V VOLTS” LIGHT DOES NOT ILLUMINATE, MOVE “PLUG B” TO OTHER OUTLETS UNTIL “220VOLT” LIGHT ILLUMINATES. NOTE: Only about half the outlets in any facility or home will complete the 220v connection.

STEP 1



STEP 2



INDICATOR LIGHT

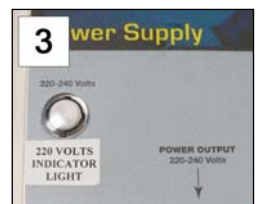

Step 3) CONNECTING ELECTRICAL POWER TO THE PDU6.5.

Set the PDU6.5 power switch to the “OFF” position before connecting.
(See photo 1)

- A) Connect the # 862331 10’ twist lock lead line cord to the unit by inserting the female plug end of the lead line to the recessed male connection of the unit. Insert plug and twist to lock in place (See photo 2)
- B) Connect the male end of the #862331 10’ lead line cord to the female receptacle of the Quick 220 ® Converter and twist to lock in place. (See photo 3)
- C) Switch the circuit breaker located on the side of the Quick 220 Converter box to the “ON” position (See photo 4)
- D) The PDU6.5 system can now be turned on by placing the power switch located on the control panel to the “ON” position. (See photo 5)

STEP 3

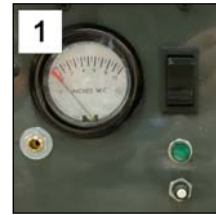

STEP 3A



STEP 3B

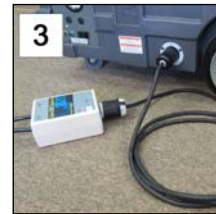

STEP 3C



STEP 3D



OPTION 2

ELECTRICAL SET-UP WHEN USING 1 – 220V CIRCUIT.

Step 1) When using and plugging directly into a 220V (1 Phase) 20 amp (minimum) circuit.

Turn the power switch located on the control panel of the PDU6.5 control panel to the “OFF” position

Step 2) Using the #862332 25’ 220V lead line cord (not included), connect the female end of the cord to the recessed male plug on the PDU6.5 and twist to lock into place

Step 3) Connect the male end of the #862332 25’ 220V lead line directly into a 220V single phase 20 amp outlet.

Step 4) the PDU6.5 system can now be turned on by placing the power switch located on the control panel to the “ON” position.

FILTER AND SET-UP PROCEDURES

- 1) Turn off and unplug unit.
- 2) Remove the top cover w/12" flange by loosening the twist lock latches. (see photo 1)
- 3) Place the HEPA filter in the HEPA filter cabinet, make sure the air flow arrows on filter are pointing towards the blower assembly. Use the 4 bolts and tabs to secure the HEPA filter. (see photo 2)
- 4) Connect the spacer frame by using the 4 – 5/16 nuts. (see photo 3)
- 5) Place the Merv 11 Cube Filter inside the top cover filter holding channel. (see photo 4)
- 6) Place the top cover w/12" flange on the housing and secure into place using the 4 – twist lock latches. (see photo 5)
- 7) Connect the 12" clear hose to the 12" intake flange on the top cover and using the hose clamp provided, secure tightly.
- 8) Mount the duct intake collar at your access point.
- 9) Connect the 12" clear hose to the duct intake collar using the hose clamp provided.
- 10) Unit is ready for operation.

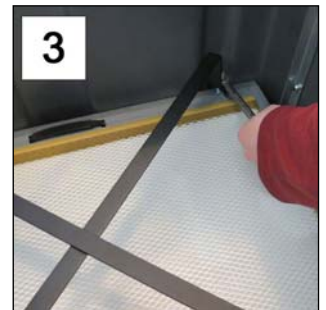

FILTER CHANGING PROCEDURE

Your NIKRO Portable Air Duct Cleaner is equipped with a filter monitor gauge which is located on the lower filter cabinet. When this gauge reads 5" or higher, the following steps should be taken:

- 1) Turn off unit.
- 2) Inspect the 12" clear hose assuring that it is not kinked or clogged.
- 3) Empty or replace the Merv 11 cube filter.
- 4) If gauge continues to read at 5" or higher, go to Step #5.
- 5) Replace the HEPA filter.
- 6) If gauge remains at 5" or higher DO NOT USE THE UNIT. Contact the Nikro Factory immediately.

#PDU6.5 ASSEMBLY

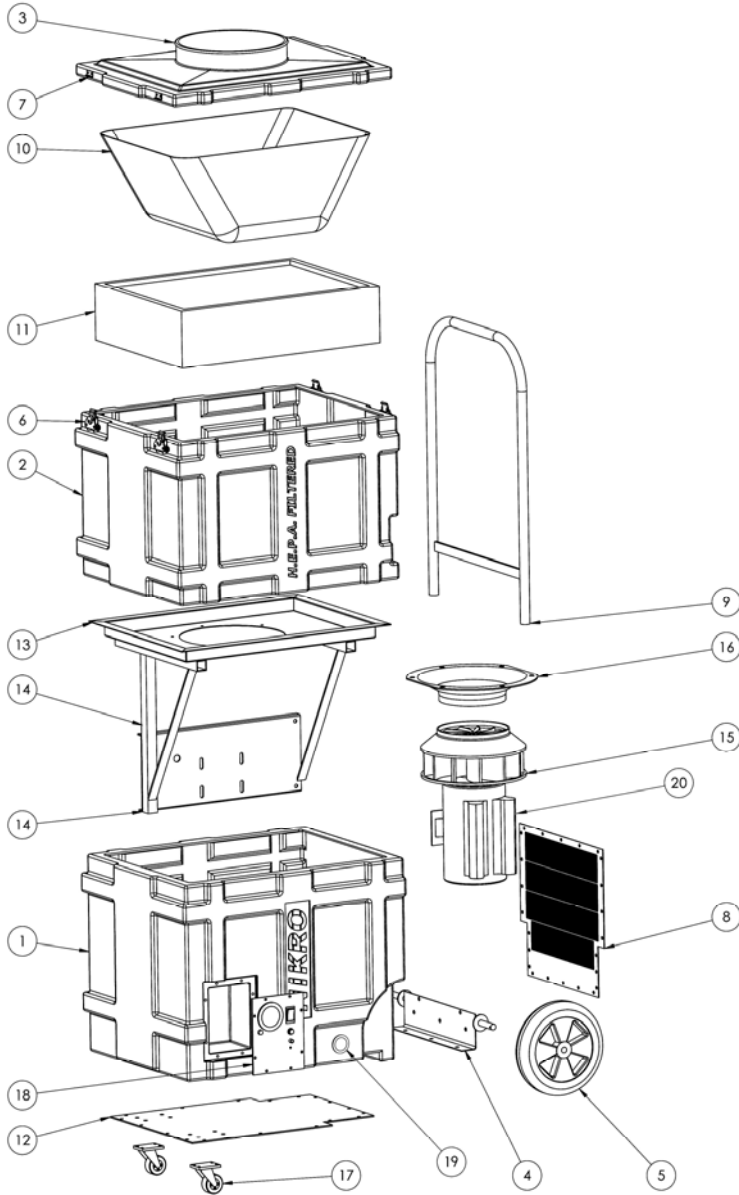

| PC NO | PART NO | PART NAME | QTY |
|-----------|----------|------------------------------|-----|
| 1 | 862233 | MOTOR CABINET | 1 |
| 2 | 862234 | FILTER CABINET | 1 |
| 3 | 862232 | DOOR | 1 |
| 4 | 862228 | AXLE BRACKET | 1 |
| 5 | 862194 | 10" WHEEL | 2 |
| 6 | 860576 | LATCH | 4 |
| 7 | 860726 | STRIKE | 4 |
| 8 | 862203 | EXHAUST PANEL | 1 |
| 9 | 862230 | HANDLE | 1 |
| 10 | 862200 | MERV 11 CUBE FILTER | 1 |
| 11 | 862323 | HEPA FILTER | 1 |
| 12 | 862202 | BOTTOM PLATE | 1 |
| 13 | 862198-M | BAFFLE | 1 |
| 14 | 862235 | MOTOR MOUNT | 1 |
| 15 | 862317 | BLOWER | 1 |
| 16 | 862319 | BLOWER CONE | 1 |
| 17 | 862304 | 3" CASTER | 2 |
| 18 | 862197 | CONTROL PANEL | 1 |
| 19 | 862336 | RECESSED PLUG | 1 |
| 20 | 862410 | MOTOR | 1 |
| NOT SHOWN | 862670 | 4" LOCKING CASTER | 2 |
| NOT SHOWN | 862328 | REUSABLE BULK COLLECTION BAG | 1 |

#PDU6.5 CONTROL PANEL



| PC NO | PART NO | PART NAME | QTY |
|-------|---------|---------------------|-----|
| 1 | 862325 | GAUGE | 1 |
| 2 | 861067 | RUNNING LIGHT | 1 |
| 3 | 862293 | SWITCH | 1 |
| 4 | 860570 | BREAKER | 1 |
| 5 | 862228 | CONTROL PANEL PLATE | 1 |
| 6 | 860721 | HOSE BARB | 1 |
| 7 | 860722 | HOSE BARB NUT | 1 |

WARRANTY

NIKRO PDU6.5 is warranted for 3 years from the date delivered to the original end user and may not be assigned or transferred.

Parts, which become defective due to faulty workmanship or materials during normal use in this period will be repaired or exchanged at no charge if returned and approved by an authorized NIKRO service center. All replaced or repaired parts shall only be warranted for the remainder of the original three year warranty period.

After the expiration of the three year warranty, all warranties on this unit including fitness for a proposed usage or purpose will become void.

The end user shall be responsible for freight charges incurred to deliver warranted product to an approved NIKRO service center. NIKRO shall be responsible for freight charges incurred in returning unit to customer, but not to exceed the original freight charges to customer.

It shall be wholly NIKRO's decision to repair, replace or refund the purchase price of any such defective goods.

This warranty does not apply to normal wear and tear, neglect, misuse, abuse or incorrect installation. If any other replacement parts, filters or attachments are used other than original NIKRO parts, this warranty will become void.

NIKRO disclaims responsibility for loss of production, profits, goodwill or any other costs that may indirectly occur due to the failure of this product.

H.E.P.A. FILTER STANDARDS AND CERTIFICATION

All NIKRO H.E.P.A. filters are manufactured and individually tested using the MIL-STD 282 D.O.P. test, or the IEST-RP-CC-001.3 test method.

Each filter is tested and certified to have a minimum efficiency of 99.97% @ 0.3 micron particles. All filters are then individually labeled and registered by the manufacturer.

All H.E.P.A. filters used in NIKRO equipment meet, and in most cases, exceed the minimum standard of 99.97% efficiency @ 0.3 micron particles, and comply with OSHA and EPA standards for cleaning the air of toxic and nuisance dust such as mold, lead and asbestos.