

NIKRO

MODEL PDU4000 UPRIGHT AIR DUCT CLEANING SYSTEM

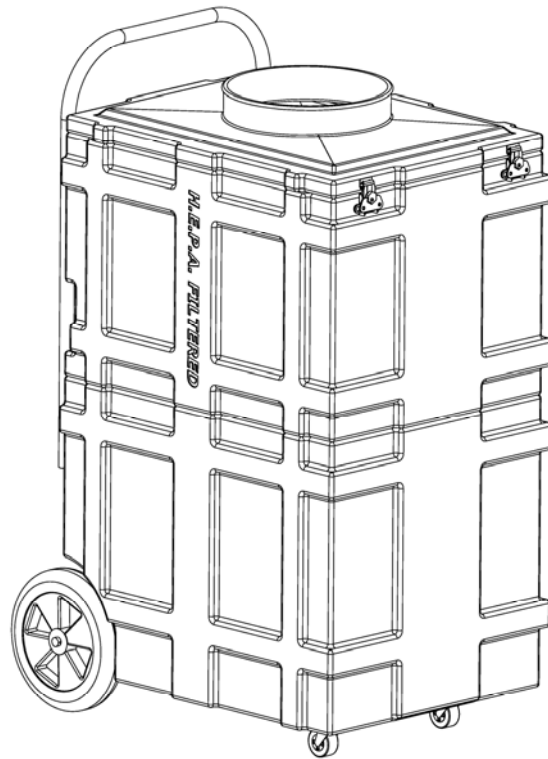

INSTRUCTION MANUAL

IMPORTANT SAFETY INSTRUCTIONS
READ ALL INSTRUCTIONS BEFORE USING THIS MACHINE.

“READ AND SAVE THESE INSTRUCTIONS”

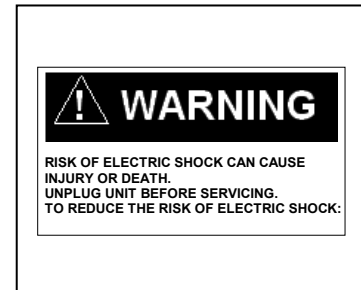

RISK OF FIRE, ELECTRIC SHOCK, OR PERSONAL INJURY

- Unit must be electrically grounded.
- Do not operate in standing water.
- If electrical components become wet, allow them to dry completely before using.
- Unplug unit before performing any maintenance, filter changes or cleaning.
- Inspect cord and plug for damage before use.
- Do not touch cord with wet hands or while standing on wet surface.
- Do not operate in flammable or explosive areas.
- Do not clean unit while plugged in.
- This unit has been designed for indoor use only.
- Do not use to exhaust hazardous or explosive materials or vapors

IMPORTANT SAFETY INSTRUCTIONS

- a. “Do not operate any unit with a damaged cord or plug. Discard unit or return it to an authorized service facility for examination and/or repair.”
- b. “Do not run cord under carpeting. Do not cover cord with throw rugs, runners, or similar coverings.
- c. Arrange cord away from traffic area and where it will not be tripped over.”



All Nikro Industries Inc. products that have rated efficiencies of 99.97% @ 0.3 microns and/or 99.99% @ 0.3 microns, have H.E.P.A. filters that have been individually tested to meet these minimum efficiencies.

Although all the filters have been pre-tested, the possibility of leaks or filter failure due to handling, transportation, punctures, loaded filters, moisture, wear and tear, etc., does exist.

Therefore, when using this equipment in highly sensitive areas or where any release of particles above and beyond the minimum efficiencies would be detrimental and harmful to humans, plants or property; it is strongly recommended that the units be individually tested prior to their use.

This is to assure that they are maintaining the efficiency levels, which they were designed to filter out.

**FAILURE TO DO SO COULD RESULT IN SERIOUS HARM TO HUMAN LIFE,
PLANT LIFE AND/OR PROPERTY.**



BACKDRAFTING AND CARBON MONOXIDE FUMES

To prevent the backdrafting of deadly carbon monoxide, when using your PDU4000 to create a negative pressure in a containment area, turn off all open combustion devices such as but not limited to fireplaces, hot water heaters, furnaces, boilers etc.

1115 N. Ellsworth Ave., Villa Park, IL 60181
Telephone: 630-530-0558 FAX: 630-530-0740 Toll Free: 800-875-6457

PRODUCT INSPECTION

1. Thoroughly inspect your machine for any shipping damage.
2. Your machine has already been thoroughly tested at the Nikro Industries manufacturing plant prior to shipping.
3. Please do not discard any of the packaging until you have inspected the vacuum and it is operational. Make sure the contents are intact and complete. If there are any missing parts please contact Nikro Industries immediately.

CONTENTS

1 - #PDU4000 – Air Duct Cleaning System

1 – #860147 – 12” x 25’ PVC Flex Duct

2 – #860249 – 12” Quick Connect Hose Clamps

1 – #860111 – 12” Duct Mounting Flange

Replacement Filters:

#862328 – Reusable Bulk Collection Bag (1 installed in Unit)

#862200 – Merv 11 Cube Filter (1 installed in Unit)

#862323 – HEPA Filter (1 installed in Unit)



#PDU4000



#860147



#860249



#860111

Your #PDU4000 Portable Air Duct Cleaning System has been thoroughly tested and inspected at the factory and is fully assembled and ready for use. However, prior to plugging the unit in, inspect it for any damage that may have incurred during shipping.

ELECTRICAL RATING:

115V 11 Amps 60 HZ - Each Motor
Use minimum of 12-3 gauge extension cords.
Each motor cord requires a separate 15 amp or 20 amp circuit.

FILTER AND SET-UP PROCEDURES

- 1) Turn off and unplug unit.
- 2) Remove the top cover w/12" flange by loosening the twist lock latches. (see photo 1)
- 3) Place the HEPA filter in the HEPA filter cabinet, make sure the air flow arrows on filter are pointing towards the blower assembly. Use the 4 bolts and tabs to secure the HEPA filter. (see photo 2)
- 4) Connect the spacer frame by using the 4 – 5/16 nuts. (see photo 3)
- 5) Place the Merv 11 Cube Filter inside the top cover filter holding channel. (see photo 4)
- 6) Place the top cover w/12" flange on the housing and secure into place using the 4 – twist lock latches. (see photo 5)
- 7) Connect the 12" clear hose to the 12" intake flange on the top cover and using the hose clamp provided, secure tightly.
- 8) Mount the duct intake collar at your access point.
- 9) Connect the 12" clear hose to the duct intake collar using the hose clamp provided.
- 10) Unit is ready for operation.

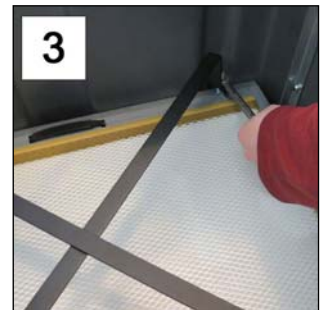

FILTER CHANGING PROCEDURE

Your Nikro Portable Air Duct Cleaner is equipped with a filter monitor gauge which is located on the lower filter cabinet. When this gauge reads 4" or higher, the following steps should be taken:

- 1) Turn off unit.
- 2) Inspect the 12" clear hose assuring that it is not kinked or clogged.
- 3) Empty or replace the Merv 11 cube filter.
- 4) If gauge continues to read at 4" or higher, go to Step #5.
- 5) Replace the HEPA filter.
- 6) If gauge remains at 4" or higher DO NOT USE THE UNIT. Contact the Nikro Factory immediately.

#PDU4000 ASSEMBLY

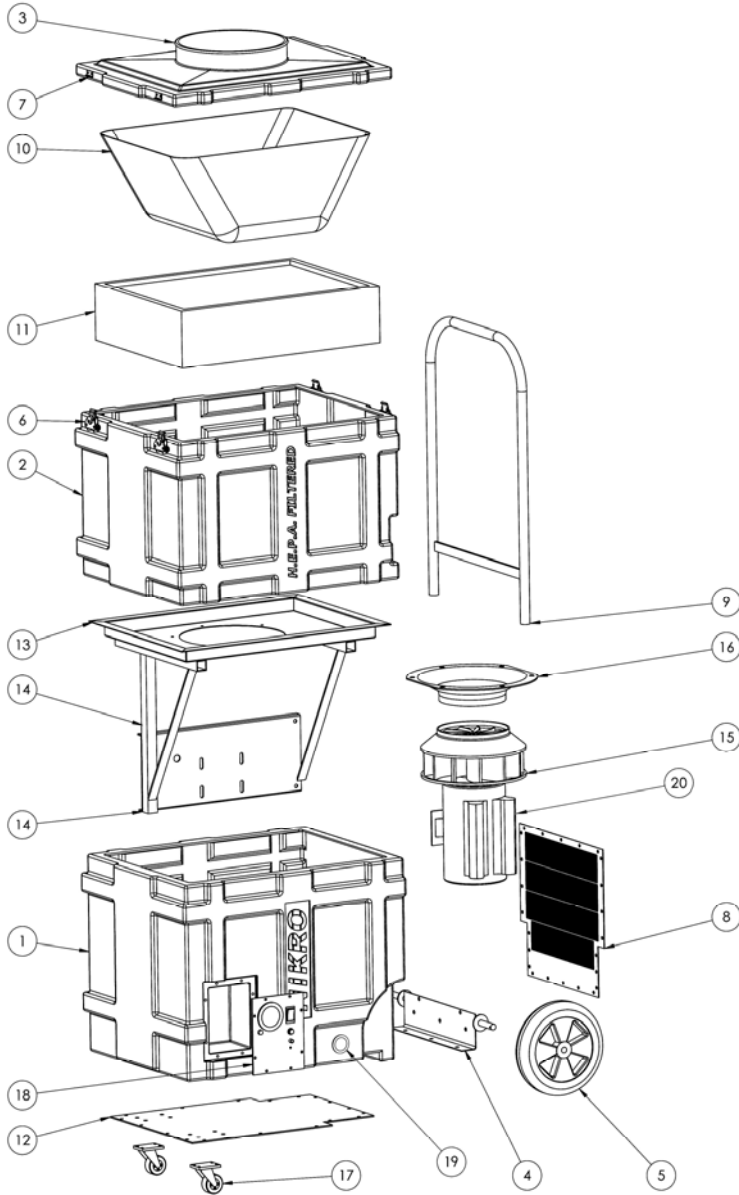

PC NO	PART NO	PART NAME	QTY
1	862233	MOTOR CABINET	1
2	862234	FILTER CABINET	1
3	862232	DOOR	1
4	862228	AXLE BRACKET	1
5	862194	10" WHEEL	2
6	860576	LATCH	4
7	860726	STRIKE	4
8	862203	EXHAUST PANEL	1
9	862230	HANDLE	1
10	862200	MERV 11 CUBE FILTER	1
11	862323	HEPA FILTER	1
12	862202	BOTTOM PLATE	1
13	862348	BAFFLE	1
14	862414	MOTOR SHELF	1
15	860694	BLOWER	2
16	862319	BLOWER CONE	2
17	862304	3" CASTER	2
18	862197	CONTROL PANEL	1
19	862294	RECESSED PLUG	2
20	860682	MOTOR	2
NOT SHOWN	862670	4" LOCKING CASTER	2
NOT SHOWN	862328	REUSABLE BULK COLLECTION BAG	1

#PDU4000 CONTROL PANEL



PC NO	PART NO	PART NAME	QTY
1	860699	GAUGE	1
2	862293	SWITCH	2
3	860722	HOSE BARB NUT	1
4	860721	HOSE BARB	1
5	860570	BREAKER	2
6	861067	RUNNING LIGHT	2
7	860722	CONTROL PANEL PLATE	1

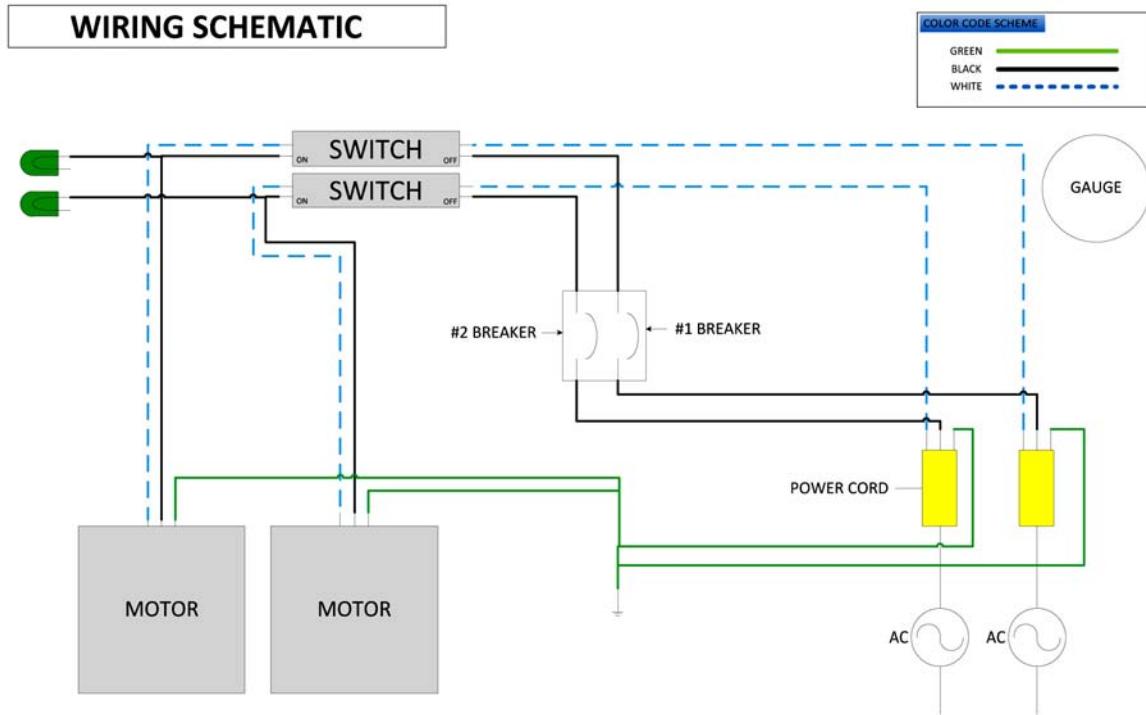

WARRANTY

Nikro PDU4000 is warranted for 3 years from the date delivered to the original end user and may not be assigned or transferred.

Parts, which become defective due to faulty workmanship or materials during normal use in this period will be repaired or exchanged at no charge if returned and approved by an authorized Nikro service center. All replaced or repaired parts shall only be warranted for the remainder of the original three year warranty period.

After the expiration of the three year warranty, all warranties on this unit including fitness for a proposed usage or purpose will become void.

The end user shall be responsible for freight charges incurred to deliver warranted product to an approved Nikro service center. Nikro shall be responsible for freight charges incurred in returning unit to customer, but not to exceed the original freight charges to customer.

It shall be wholly Nikro's decision to repair, replace or refund the purchase price of any such defective goods.

This warranty does not apply to normal wear and tear, neglect, misuse, abuse or incorrect installation. If any other replacement parts, filters or attachments are used other than original Nikro parts, this warranty will become void.

Nikro disclaims responsibility for loss of production, profits, goodwill or any other costs that may indirectly occur due to the failure of this product.

H.E.P.A. FILTER STANDARDS AND CERTIFICATION

All Nikro H.E.P.A. filters are manufactured and individually tested using the MIL-STD 282 D.O.P. test, or the IEST-RP-CC-001.3 test method.

Each filter is tested and certified to have a minimum efficiency of 99.97% @ 0.3 micron particles. All filters are then individually labeled and registered by the manufacturer.

All H.E.P.A. filters used in Nikro equipment meet, and in most cases, exceed the minimum standard of 99.97% efficiency @ 0.3 micron particles, and comply with OSHA and EPA standards for cleaning the air of toxic and nuisance dust such as mold, lead and asbestos.